

TORNADO

By Duraquip

2 COMPARTMENT WITH LIQUID SPECIFICATIONS

GA DRAWING / HOPPER SPLITS

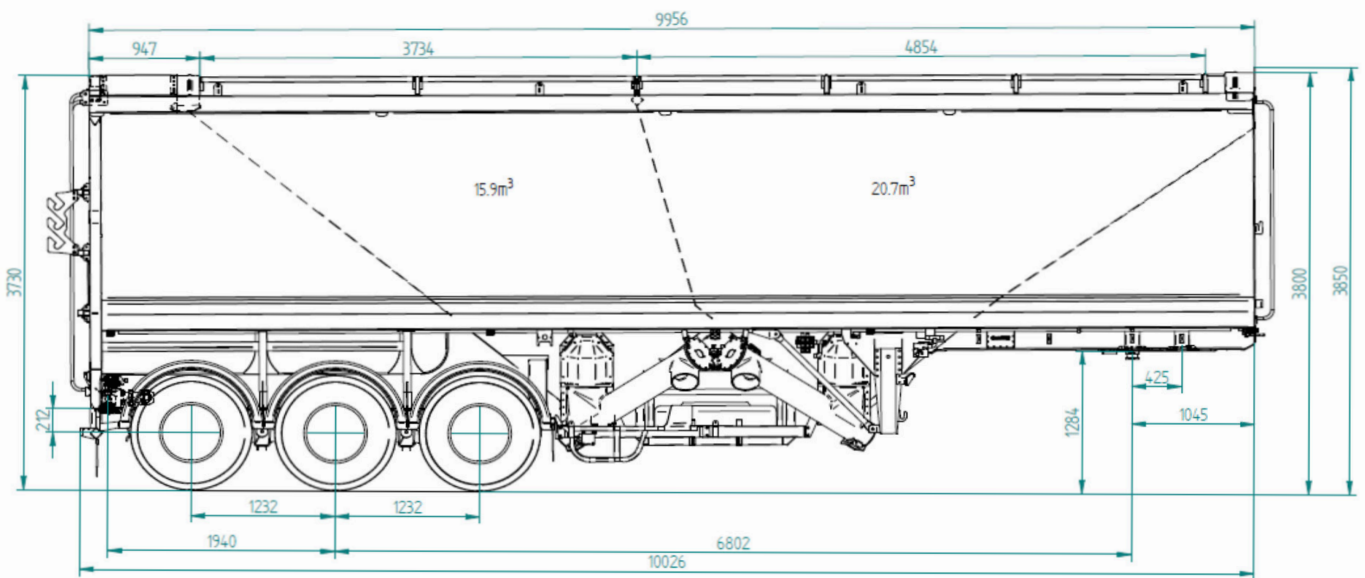

HOPPER CAPACITIES

TOTAL	36.4M3	WHEAT	BARLEY	FERTILISER
HOPPER 1	20.7m3	16.56T	14.5T	20.7T
HOPPER 2	15.7m3	12.6T	11.0T	15.75T
REAR Liquid Tank Combined	1600 L			
Rear Hopper N/A with Liquid Option				
TARE WEIGHT 9.1T				

SUB-FRAME COLOURS



Call our knowledgeable sales team today to discuss the TORNADO and which model will best suit your operations!



1800 27 1800 | sales@duraquip.com.au